

LISTE DE PIÈCES / PARTS LIST			
ITEM	QTY	PART NUMBER	DESCRIPTION
1	1	AE14001	INTERRUPTEUR À VIDE - 1/2" M x 1/2" F - VACUUM SWITCH
2	1	AS0019	BORNIER DE MISE À LA TERRE - GROUNG LUG
3	1	AS0025	PROTECTEUR DE CADRAN DE SURVEILLANCE VAC.- GAUGE PROTECTOR FOR VAC. MONITOR
4	4	AS0044	Fer Angle 1/4" x 2" x 2"
5	2	AS1101	OUILLET DE MANUTENTION RHC - LIFTING LUG
6	112.250 in	AX04064102	BARRE D'ACIER - 0.2500" x 4.000" - FLAT BAR
7	1	BF00006	BRIDE FORGÉE - 1/4" NPT - FORGED FLANGE
8	1	BF00013	BRIDE FORGÉE PLATE - 1/2" NPT - FLAT FORGED FLANGE
9	1	BF00053C	BRIDE FORGÉE COURBÉE TYPE MANCHON - 2" NPT - COUPLING STYLE FORGED CURVED FLANGE
10	1	BO00013	BOUCHON FILETÉ - 1/2" NPT - SQUARE PLUG
11	1	BO00051	BOUCHON FILETÉ - 2" NPT - PIPE PLUG
12	1	CA02005G	COUDE D'EVENT INTERSTITIEL - 2" - INTERSTITIAL VENT, ELBOW
13	1	CR27097	COUVERCLE ROND - 12ga 37 3/4" DIA - ROUND TANK HEAD
14	1	CR27099	COUVERCLE ROND - 12ga 38 1/4" DIA - ROUND TANK HEAD
15	1	CR46097	COUVERCLE ROND - 7ga 37.750" DIA - ROUND TANK HEAD
16	1	EP0126	VACUUM MONITORING & INSTERTITIAL VENT STICKER
17	1	EP0248	AUTOCOLLANT - 10 PLUS - STICKER
18	1	EP0251	AUTOCOLLANT - GRANBY INDUSTRIES 4X12 - STICKER
19	1	EP0321-2	AUTOCOLLANT PIÈCE - PART NUMBER STICKER
20	1	EP321-1	AUTOCOLLANT- ULC-S602 - LISTING MARK
21	1	FA27153302	HR STEEL 0.093" min. 58 1/2" X 119 1/8"
22	1	FA27153314	HR STEEL 0.093" min. x 58 1/2" x 123 "
23	1	GILKITVACUUM	COMPOSANTES DE - VACUUM - COMPONENTS
24	8	MD02051CAP	DEMI-MANCHON CAPPÉ - 2" NPT - HALF COUPLING CAPPED

- Note fabrication :
1. Installer plug 1/2" en métal et faire le vacuum (5 jours)
  2. Sabler le réservoir
  3. Enlever plug 1/2" de métal, remplacer par bouchon bleu 1/2"
  4. Peinturer Polyuréthane (Futura)
  5. Enlever bouchon bleu 1/2", remplacer par plug 1/2" de métal
  6. Peinturer couche de finition (blanc)

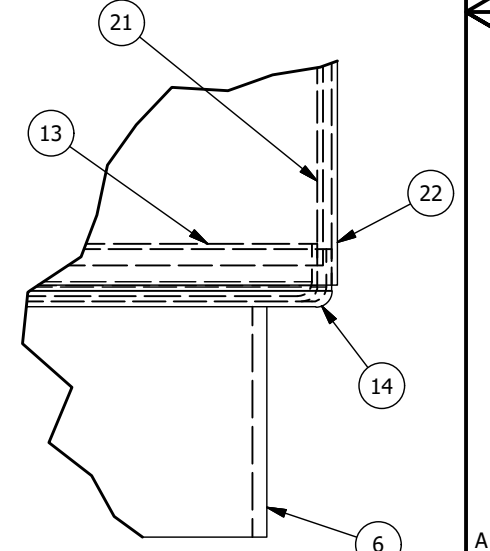
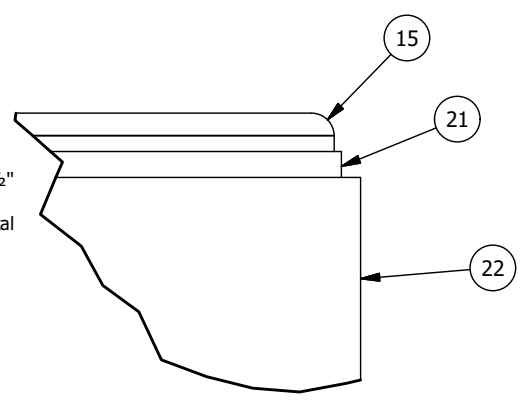

- NOTES:
1. AIR / SOAP TEST TO 35 KPa (5 PSI) MAX.
  2. INTERIOR FINISH: CLEAN OF DEBRIS ETC.
  3. EXTERIOR FINISH:
    - 3.1 BLAST CLEAN
    - 3.2 APPLY 0.010" OF POLYURETHANE
    - 3.3 APPLY WHITE POLYURETHANE ENAMEL 751 (PE0060ET AND PE0061ET)

Ce dessin est la propriété exclusive de Industries Granby, SEC. Aucune partie de ce dessin ne peut être utilisée ou reproduite sans sa permission écrite. This drawing is the exclusive property of Granby Industries LP. No part of this drawing may be used or reproduced in any manner without its written permission.			
TOLÉRANCES LINÉAIRES, LINEAR STD TOLERANCES		Description de la révision / Revision description	
0 OR FRAC. (X/X) -> ± 0.5"	0.00 -> ± 0.125"		
0.0 -> ± 0.25"	0.000 -> ± 0.0625"		
TOLÉRANCES ANGULAIRES, ANGULAR STD TOLERANCES		Dessiné par / Drawn by	
0 -> ± 2 DEG.	0.00 -> ± 0.1 DEG.	S. Potvin	
Les soudures doivent respecter la spécification SI-0039. Tank welds must respect SI-0039 specifications.		Approuvé par / Approved by :	
Poids Approx. / Approx. Weight		Unités / Units	Echelle / Scale
547 lbmass		INCHES	0.06 : 1
		Feuille / Sheet	1 / 1
		Industries Granby S.E.C., Granby Industries L.P. © 2018 Industries Granby, SEC. Granby Industries LP	
		Format / Size	No de la pièce / Part no.
		B	VCD22250PCAA
		REV	E.
Description / Title			
RÉSERVOIR VERTICAL D/P - ULC-S602 250 I.G. 10PLUS - VERTICAL D/W TANK			